

ZKB Series

磁粉式電磁煞車器 Magnetic Particle Brake

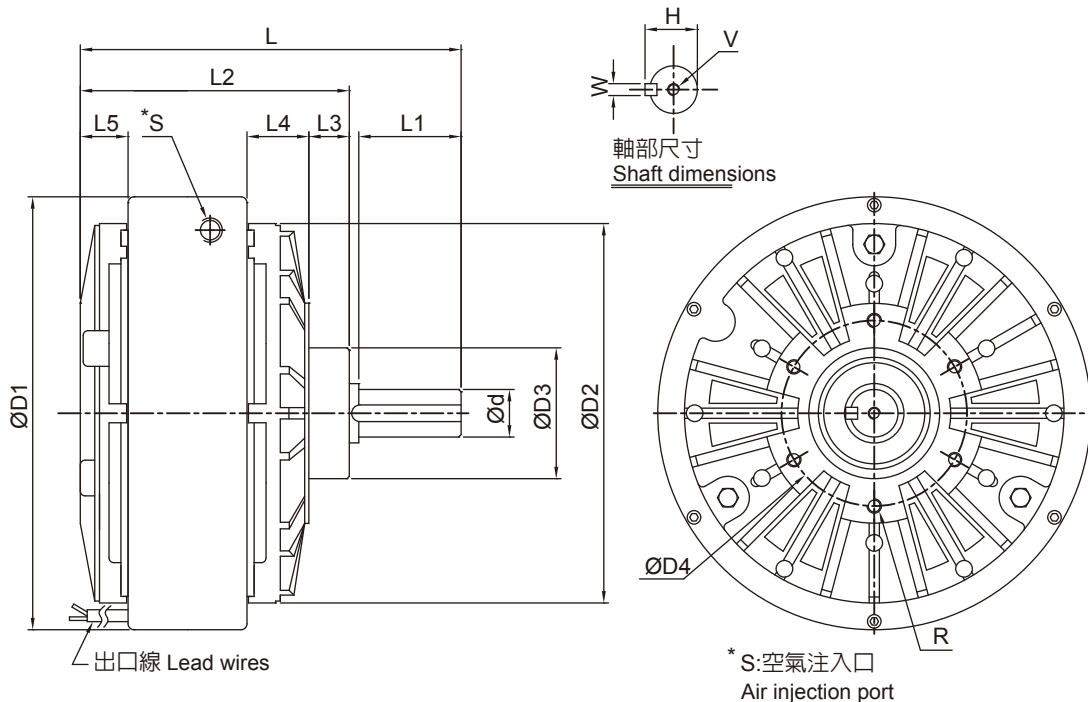

型號 MODEL	ZKB1S2AA	ZKB2S5AA	ZKB005AA	ZKB010AA	ZKB020AA	ZKB040AA	
定格轉距 [kgm](Nm) Rated torque	1.2 (12)	2.5 (25)	5 (50)	10(100)	20 (200)	40 (400)	
容量 Capacity DC24V (75°C)	電流 (A) Current	0.94	1.24	2.15	2.4	2.7	3.5
	電力 (W) Power	22.5	30	51.5	57.6	64.8	84
	時定數 (S) Time to establish torque	0.1	0.12	0.13	0.25	0.37	0.4
慣性矩 Moment of inertia (kgm ²)	1.34×10^{-3}	3.8×10^{-3}	9.5×10^{-3}	3.5×10^{-2}	9.15×10^{-2}	2.4×10^{-1}	
強制空冷容許滑動功率 Allowable slippage rate with forced-air cooling	風壓 (Pa) Air pressure	3×10^4	5×10^4	1×10^5	6×10^4	5×10^4	2×10^5
	風量 (m ³ /min) Air volume	0.2	0.4	0.6	1.1	1.6	2.0
	功率 (W) Power	250	380	700	1100	1900	2800
重量 Weight (kg)	5.2	9	14.5	34	53	100	
最高轉速 Maximum speed (r/min)	1800						
磁粉重量 Weight of powder	20	33	60	140	225	370	
外型尺寸 Exterior dimensions	D1	152	182	219	276	325	395
	D2	126	159.5	195	260.5	301	360
	D3 (g7)	42	55	74	100	110	130
	D4	64	78	100	140	150	200
	L	131.8	155	192.4	235	274.45	336.7
	L1	29.5	43	55	64.8	69	92
	L2	98.1	108	131.3	163.5	195.85	232
	L3	15	17	30	28	30	35
	L4	25.5	26	28	46	56	66.5
	L5	14.6	15	17.3	21.5	31.85	42.5
	d (h7)	15	20	25	30	35	45
	H	17	22	28	33	38.5	48.5
	W	5		7		10	12
	V	M4*0.7P*8L	M5*0.8P*10L	M6*1P*12L	M10*1.5P*20L		
R	6-M6*1P*10L			6-M10*1.5P*15L		8-M12*P1.75*20L	
S	1/8		1/4	3/8			

【標準扭力特性】（代表範例）

Special features of standard torque (reference only)

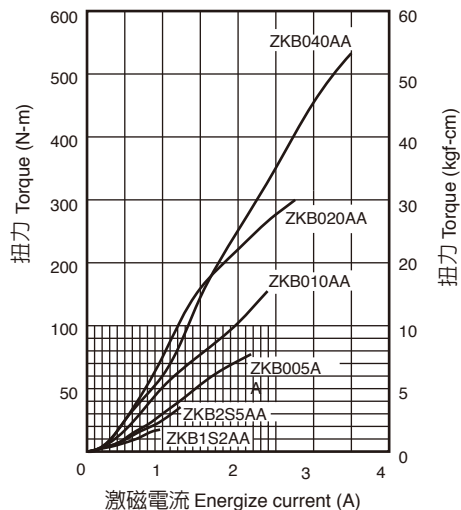

【所容許的連續滑動工作率特性（自然冷卻時）】

Allowable sustained operating efficiencies (natural cooling)

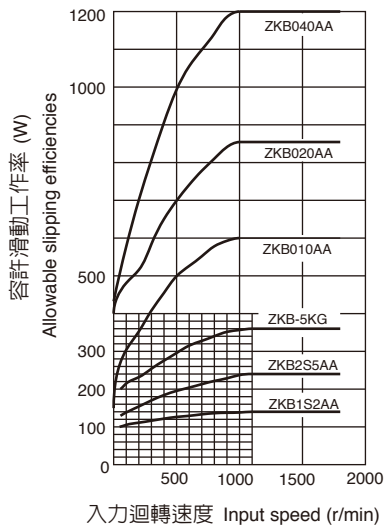

【所容許的連續滑動扭力特性（自然冷卻時）】

Allowable Sustained torque levels (natural cooling)

